

Energy in all we do

Wirkungsgradsteigerung bei Gasturbinen durch Rekuperatoren

- M. Daniel, Turbomach GmbH, Griesheim

AGENDA



1

WATT ABOUT US



2

WATT'S INSIDE: OUR PRODUCTS

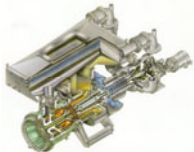

3

MERCURY 50



4

WATT'S THE FUTURE - DEVELOPMENTS

Energy in all we do

WATT ABOUT US



Energy in all we do

Company Overview

Providing Industrial Power Generation

Turbomach
A Caterpillar Company

WATT ABOUT US



Energy in all we do

- a leader in gas turbine based cogeneration
- part of Solar Turbines
with 6000 employees worldwide
of which 400 are based in Switzerland

Turbomach
A Caterpillar Company



COOPERATE STRUCTURE

CATERPILLAR®

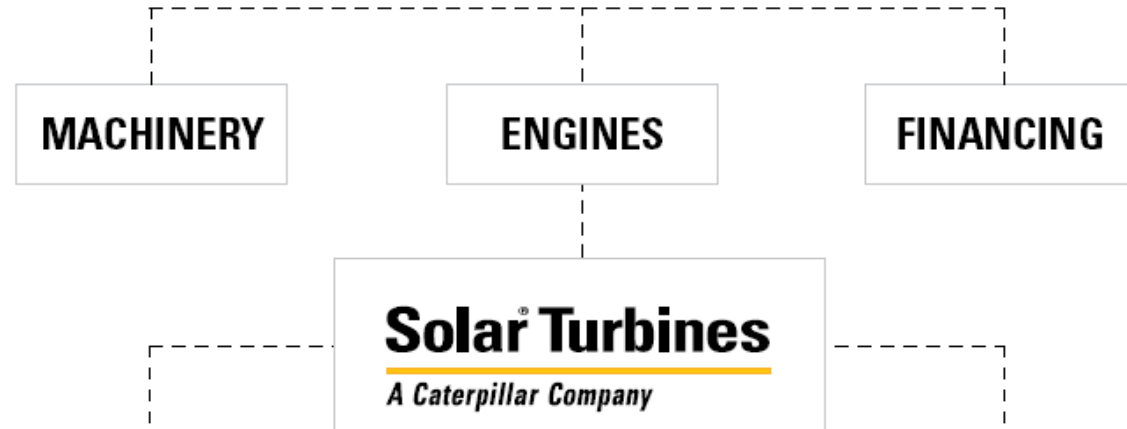

POWER GENERATION

Turbomach

A Caterpillar Company

worldwide
except US, CN, MX, JP, AU, NZ

Solar® Turbines

A Caterpillar Company

US, CN, MX, JP, AU, NZ

OIL AND GAS

Solar® Turbines

A Caterpillar Company

worldwide

Energy in all we do

Turbomach

A Caterpillar Company



FACILITIES WORLDWIDE

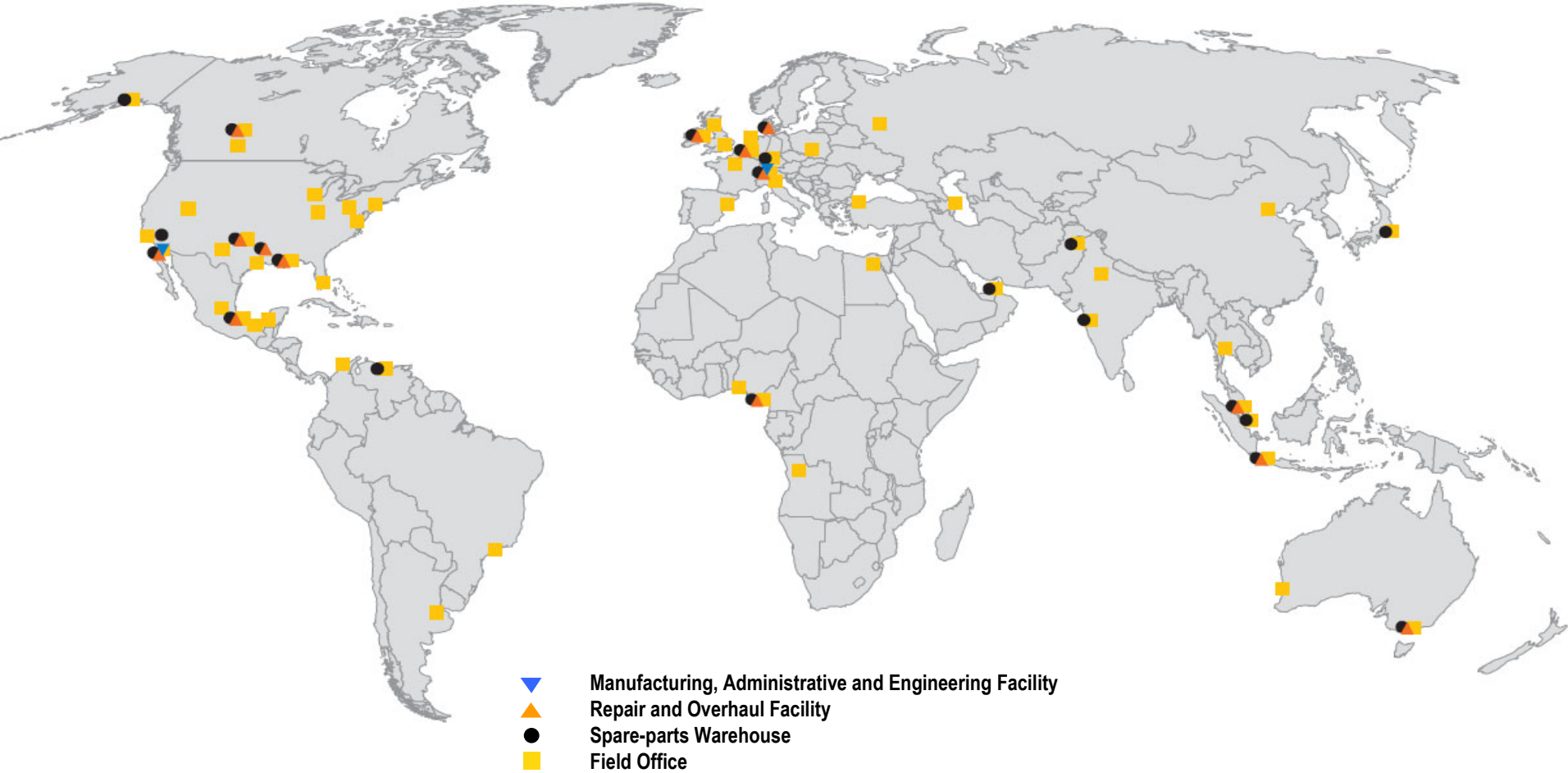

Energy in all we do

Turbomach
A Caterpillar Company

WATTS INSIDE: OUR PRODUCTS

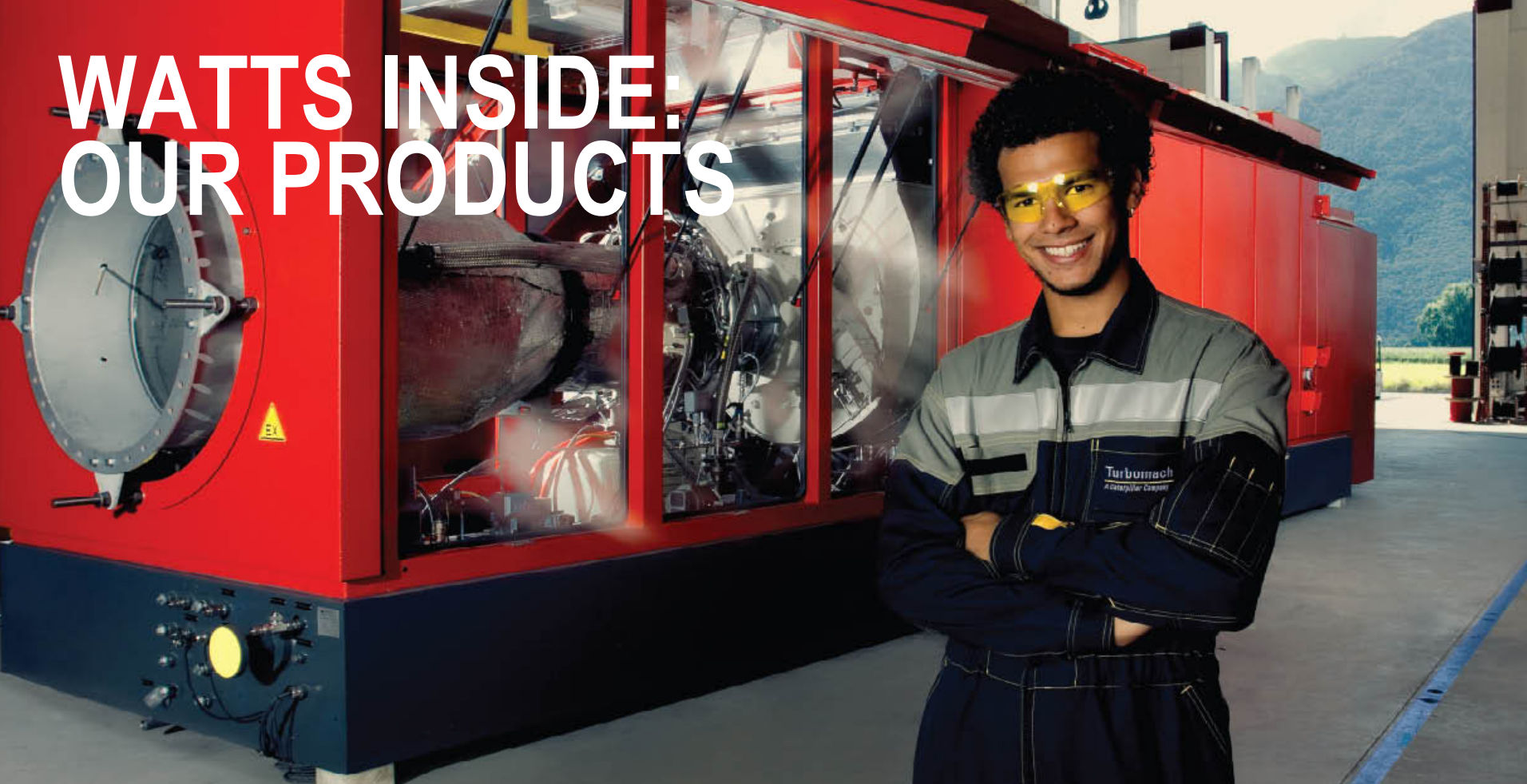

Energy in all we do

Product Range

Turbomach
A Caterpillar Company

WATTS INSIDE: OUR PRODUCTS

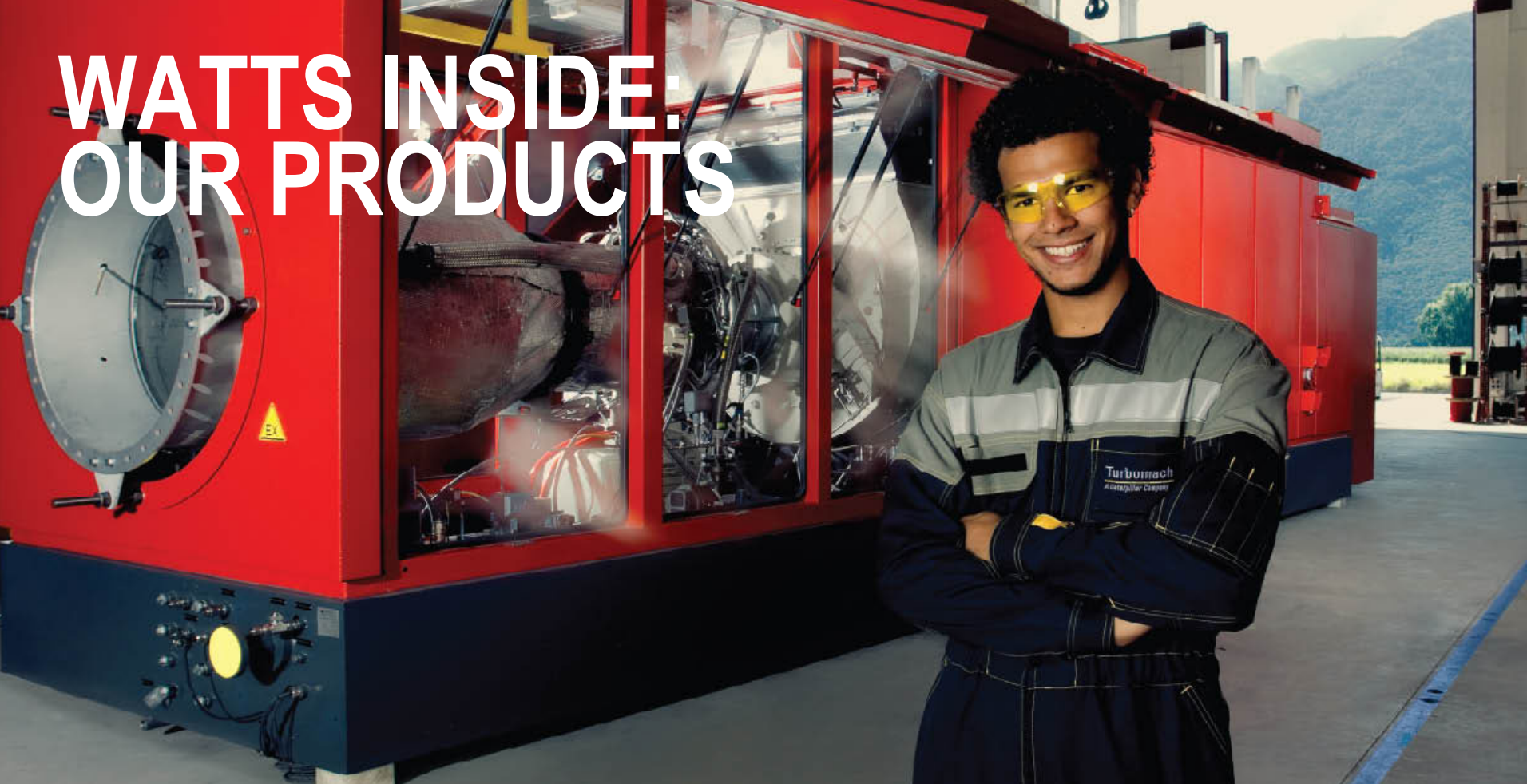

Energy in all we do

- gas turbines from 1 – 22 MW
the most comprehensive range on the market
- for complete cogeneration and power plants
up to 50 MW

Turbomach
A Caterpillar Company



INDUSTRIAL GAS TURBINES FROM 1 –25 MW

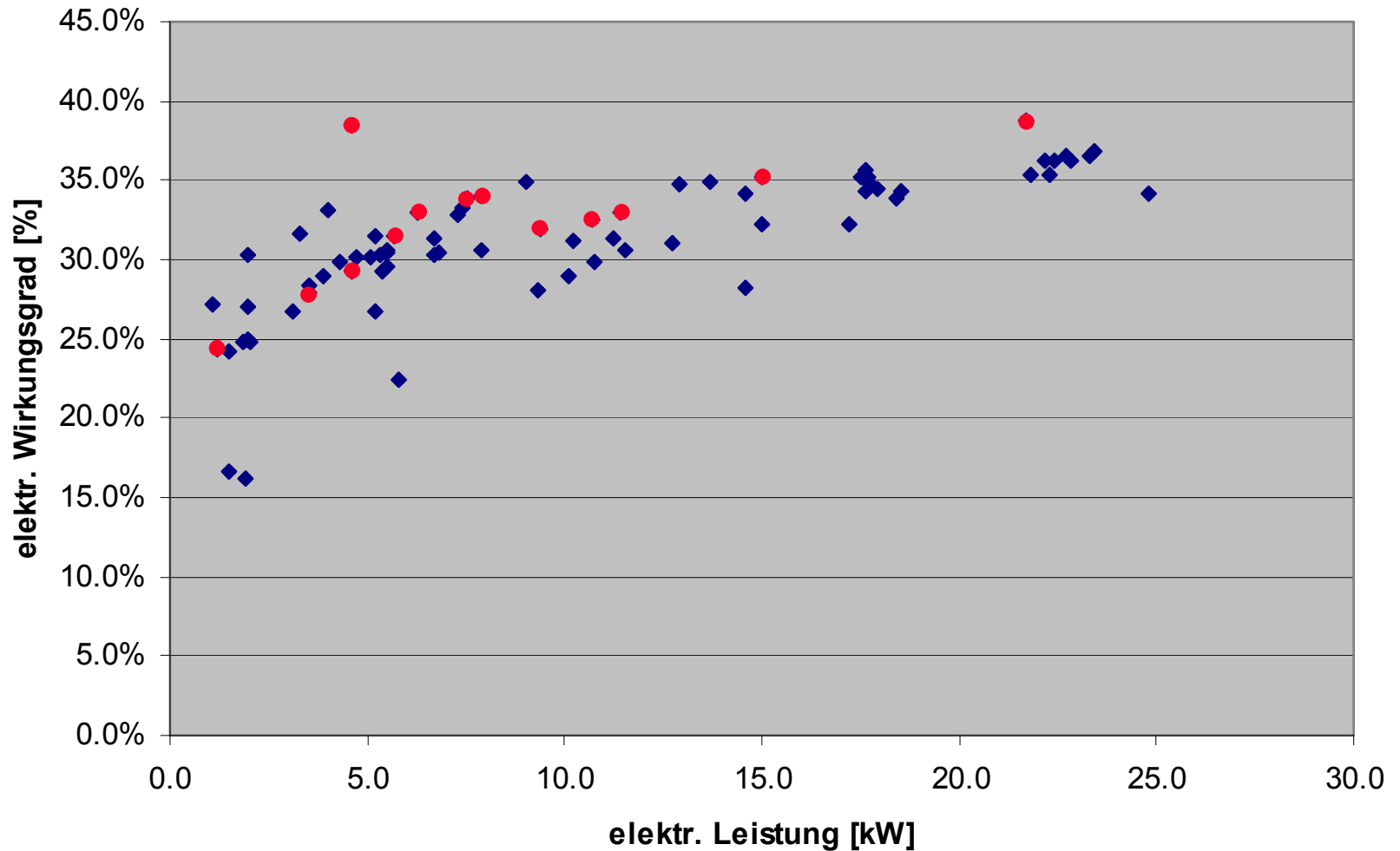

Quelle: Diesel & Gas Turbine Publications, 2009 Global Sourcing Guide



INDUSTRIAL GAS TURBINES FROM 1 –22 MW

Saturn

1.2 MW
24.3 %

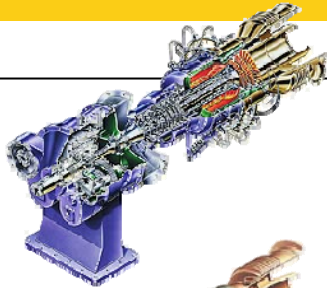

Centaur 40 / 50

3.5 / 4.6 MW
28 / 29.3 %

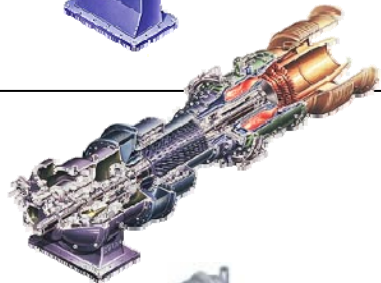

Mercury 50

4.6 MW
38.5 %

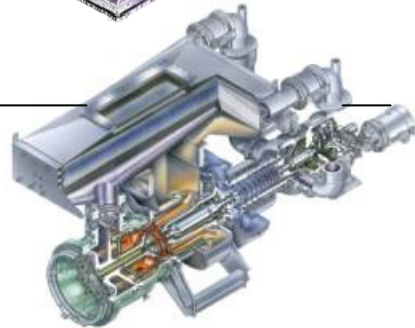

Taurus 60 / 65

5.6 / 6.3 MW
31.5 / 32.9 %

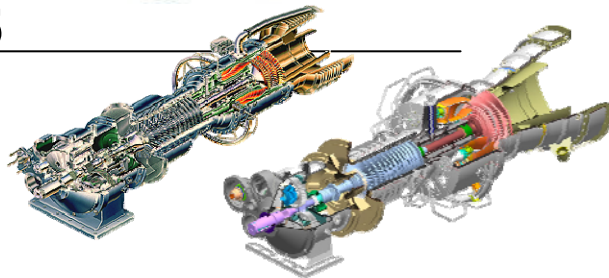

Taurus 70

7.5 MW
33.8 %

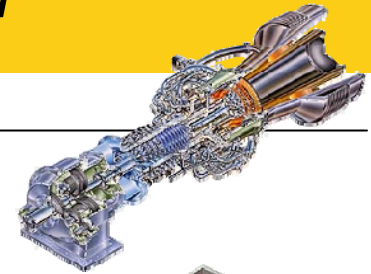

Mars 90 &100

9.4 / 11.4 MW
31.9 / 33 %

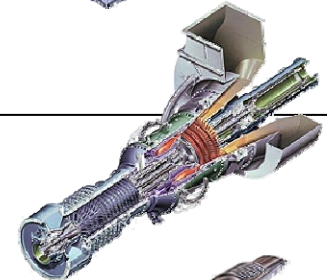

Titan 130

15 MW
35.2 %

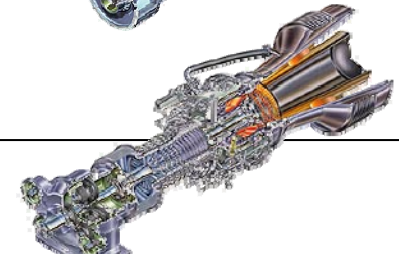

Titan 250

21.7 MW
38.8 %

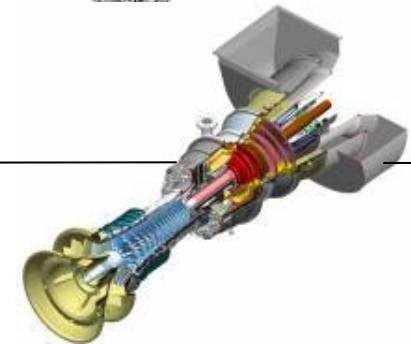

Energy in all we do



OPERATION EXPERIENCE SOLAR

Gas Turbine Experience by Package	Units Sold	Est. Hours (000's)
	Population in Units and Hours In Excess of	
Compressor Sets	3,870	590,700
Mechanical Drives	2,540	362,000
Generator Sets	7,050	508,900
Total	13,460	1,461,600

Effective: 6/30/09, © Solar Turbines Incorporated



OPERATION EXPERIENCE TURBOMACH



Industrial Sector 672 Units

Units

Paper Mills	171
Foods	109
Textiles	91
Chemical	83
Ceramics	61
Printings	24
Pharmaceutical Plants	26
Tyres	20
Chipboards	15
Breweries	13
Industrial Buildings	12
Automobile	8
Aeronautics	5
Others	34



Public & Civil Sectors 355 Units

Units

District Heating	117
Banks	56
Energy Suppliers	34
Electricity	15
Administration Buildings	17
Sewage Plants	17
Government Buildings	14
Hospitals	13
Technical Educations	8
Telecommunications	7
Airports	7
Biomass	4
Military Centers	6
Railways	3
Others	37

Energy in all we do

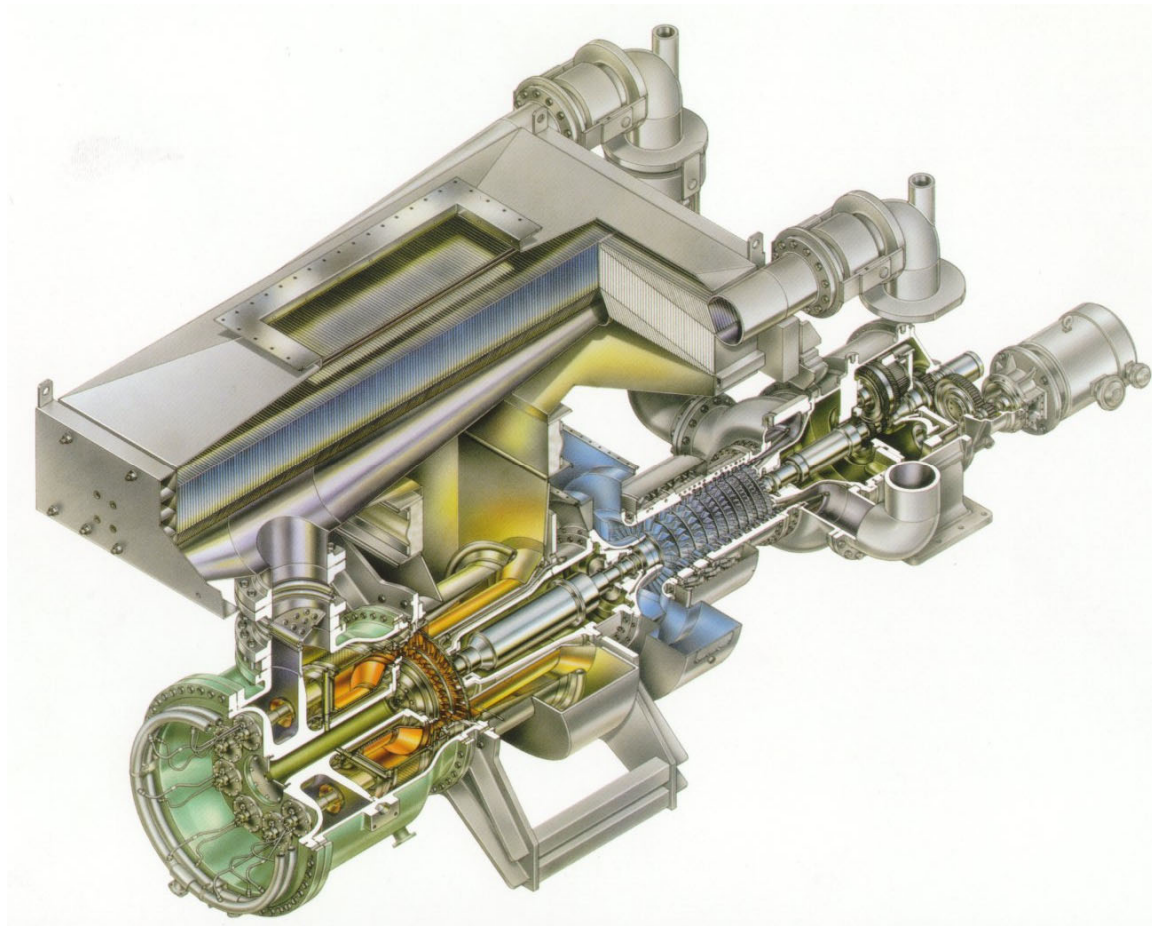

Energy in all we do

Präsentation MERCURY 50

Turbomach
A Caterpillar Company



INDUSTRIAL GAS TURBINES FROM 1 –22 MW

Saturn

1.2 MW
24.3 %

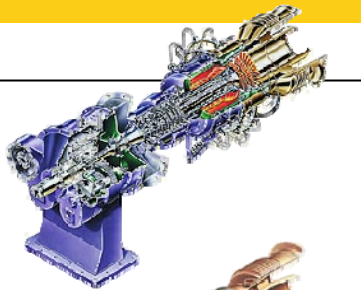

Centaur 40 / 50

3.5 / 4.6 MW
28 / 29.3 %

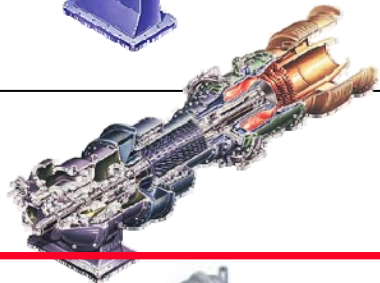

Mercury 50

4.6 MW
38.5 %

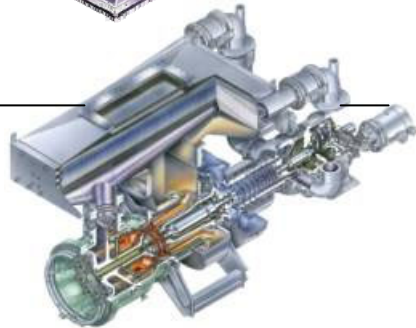

Taurus 60 / 65

5.6 / 6.3 MW
31.5 / 32.9 %

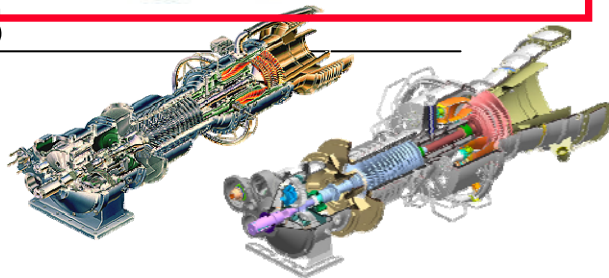

Taurus 70

7.5 MW
31.9 %

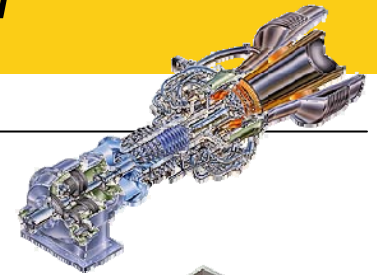

Mars 90 &100

9.4 / 11.4 MW
31.9 / 33 %

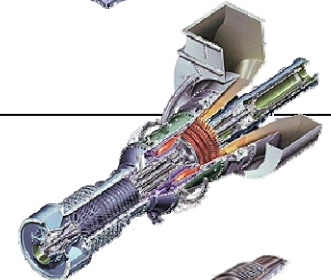

Titan 130

15 MW
35.2 %

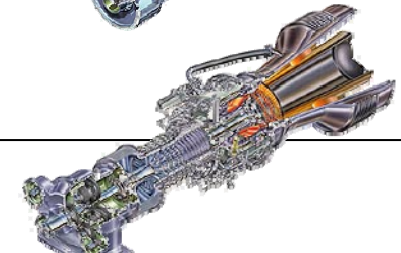

Titan 250

21.7 MW
39.2 %

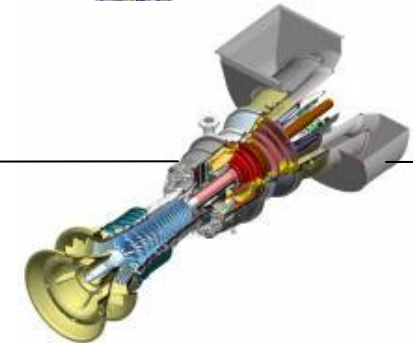

Energy in all we do

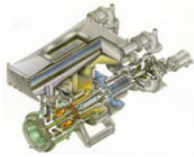

Entwicklung / Historie Mercury 50

Forschungsprojekt von SOLAR Turbines mit Unterstützung des US- Department of Energy (DOE)

Advanced Turbine Systems

- **Reduzierung der Abgasemissionen**
- **Verbesserung des elektr. Wirkungsgrad**
- **Reduzierung der Betriebskosten**
- **Einsatz alternativer Brennstoffe**

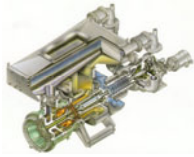

Gasturbinenprozess ohne / mit Rekuperator

Einfacher Gasturbinenprozess

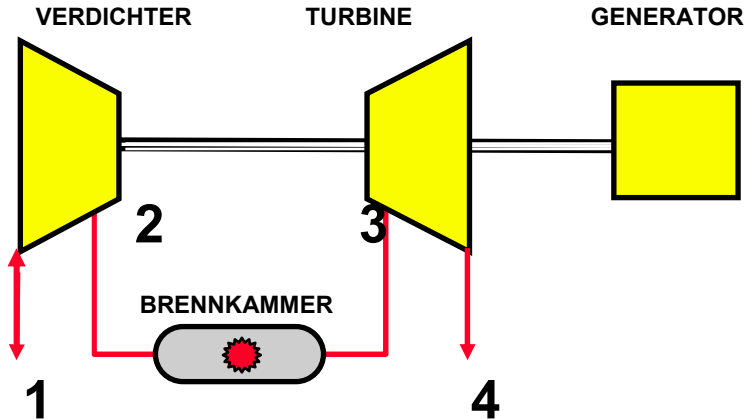

Gasturbinenprozess mit Rekuperator

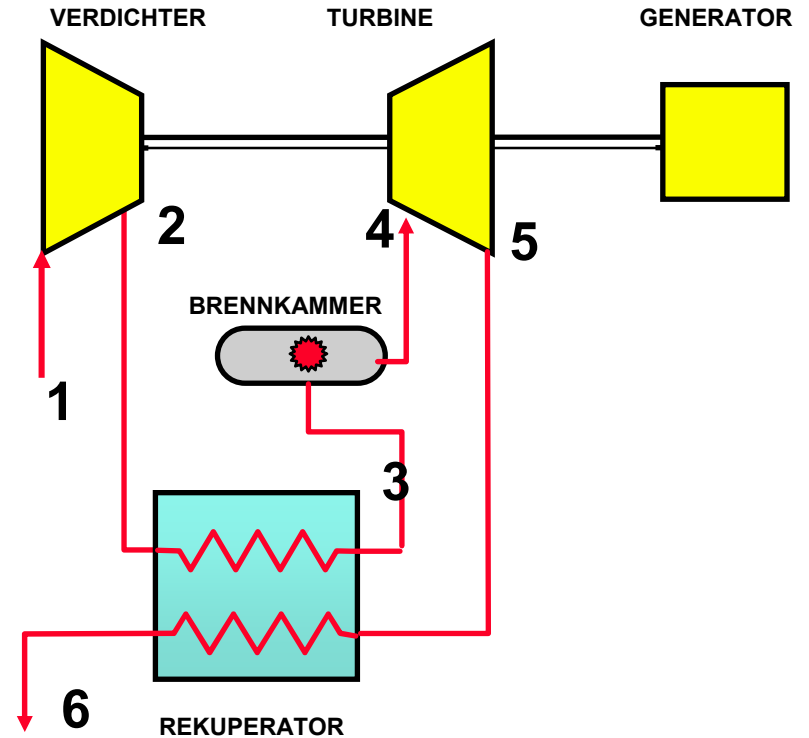

*Geringerer spezifischer Brennstoffeinsatz bzw.
höherer elektrischer Wirkungsgrad*

Mercury 50 - Wesentliche Merkmale

ACE-VERDICHTER (Advanced Component Efficiency)
→ verringerter Erdgasvordruck

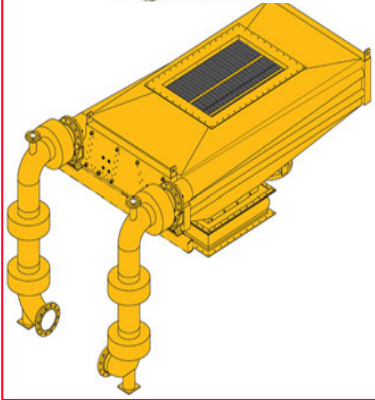

REKUPERATOR
→ Wirkungsgradsteigerung

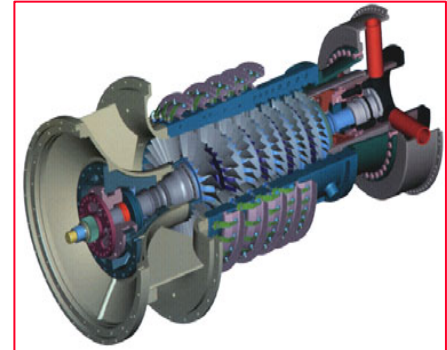

**SoloNOX
BRENNKAMMER**
→ geringe Emissionen
(„ < TA-Luft“)

**VERBESSERTE
TURBINENKÜHLUNG**
→ höhere Standzeiten

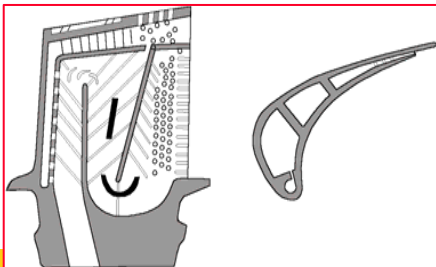
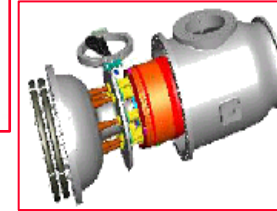
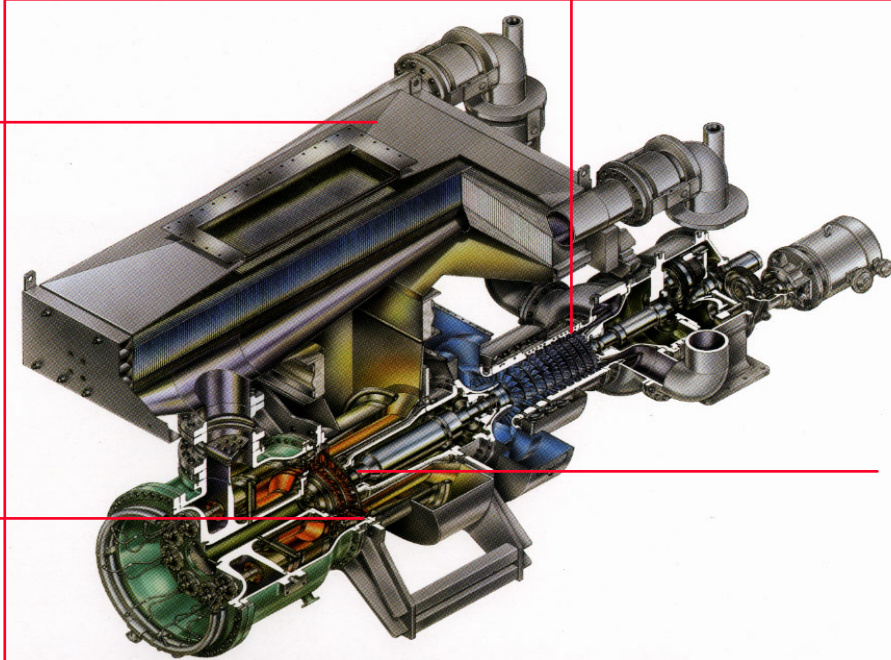

Energy in all we do

Turbomach
A Caterpillar Company

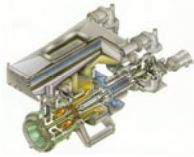

MERCURY 50 – Rekuperator Gasturbine

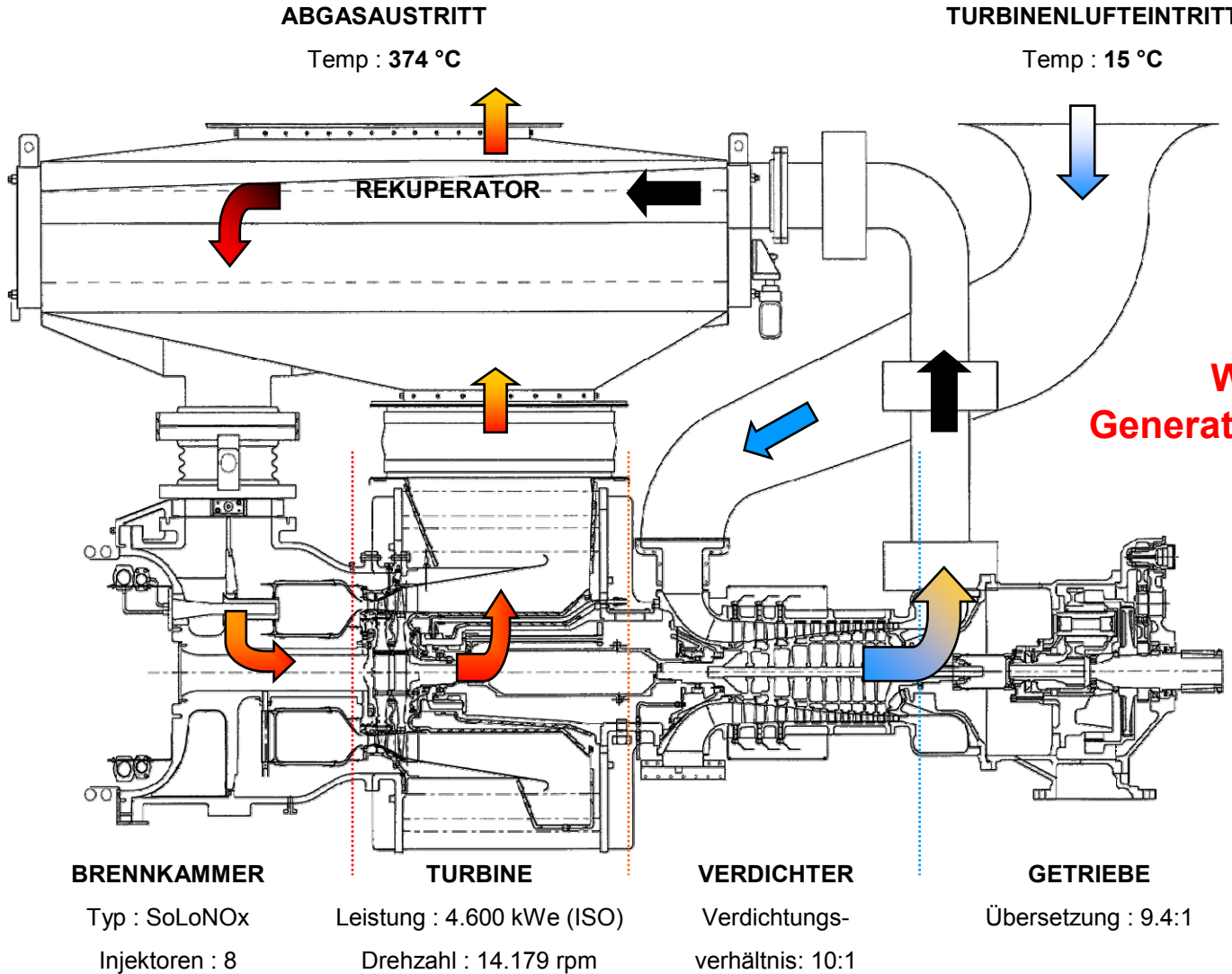

Elektrischer Wirkungsgrad an den Generatorklemmen: 38.51 %

BRENNKAMMER

Typ : SoLoNOx

Injektoren : 8

TURBINE

Leistung : 4.600 kWe (ISO)

Drehzahl : 14.179 rpm

VERDICHTER

Verdichtungs-
verhältnis: 10:1

GETRIEBE

Übersetzung : 9.4:1

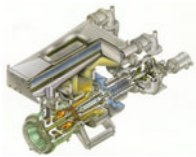

MERCURY 50 – Rekuperator

PSR
Luftzelle

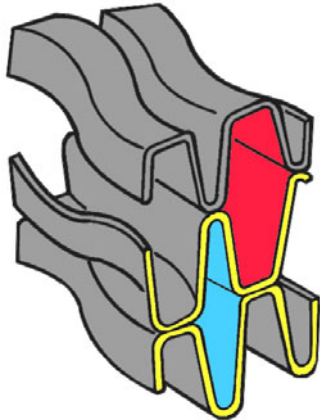

Turbinenabgas

Verbrennungsluft



Lufteintritt

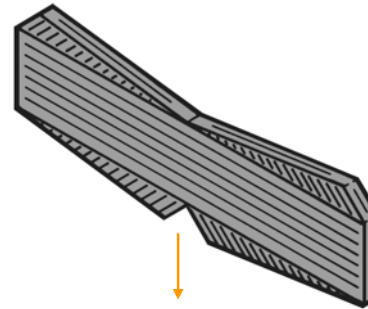

PSR
Wabe

Lufteintritt

Austritt Rek.-Luft

Rekup. Gas Austritt

PSR Kernblock



Rekup. Gas Austritt

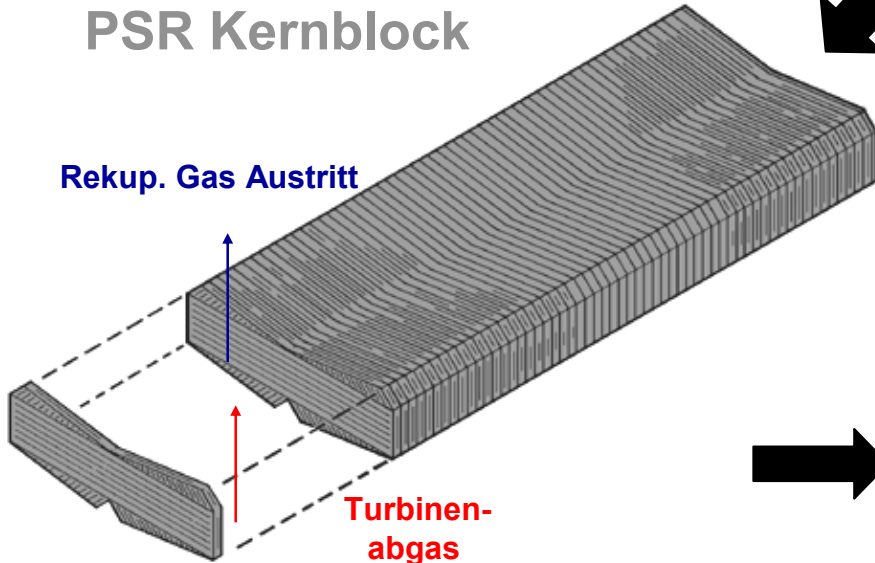

Turbinen-
abgas

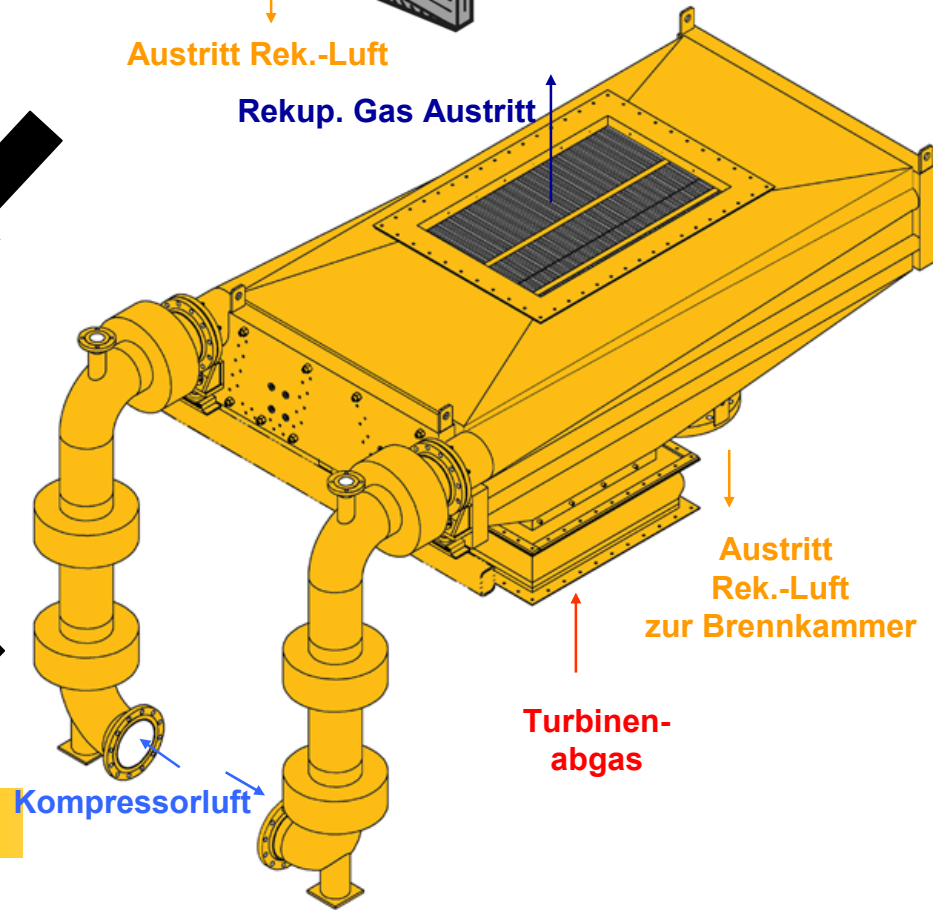

Austritt
Rek.-Luft
zur Brennkammer

Turbinen-
abgas

Kompressorluft

Energy in all we do

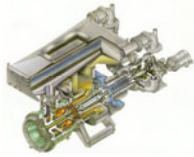

MERCURY 50 –Leistungsvergleich

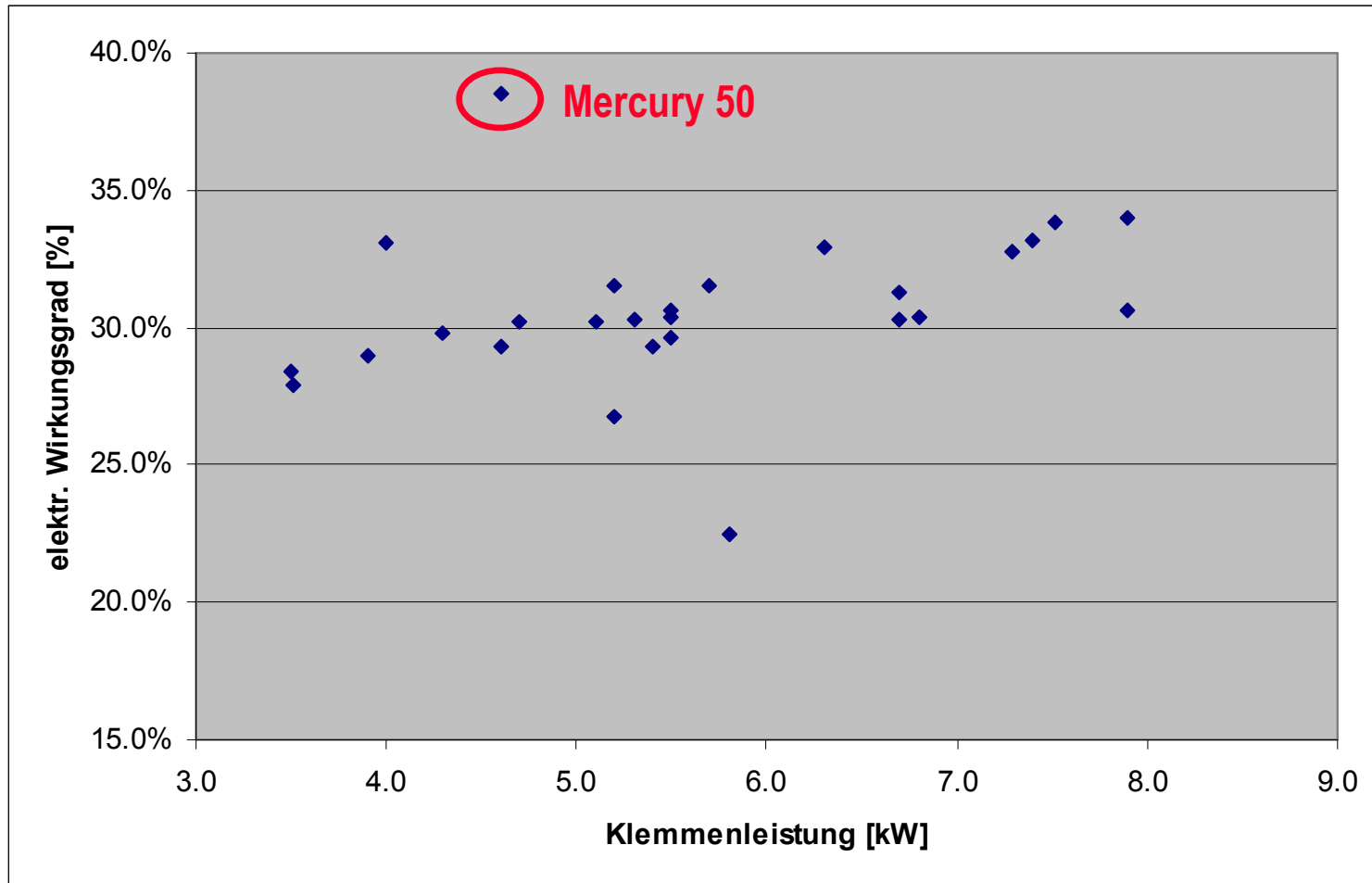

Quelle: Diesel & Gas Turbine Publications, 2009 Global Sourcing Guide

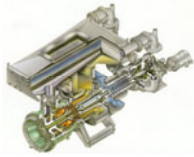

MERCURY 50 – Leistungsdaten (ISO)

Teillastverhalten Mercury 50 bei 15°C

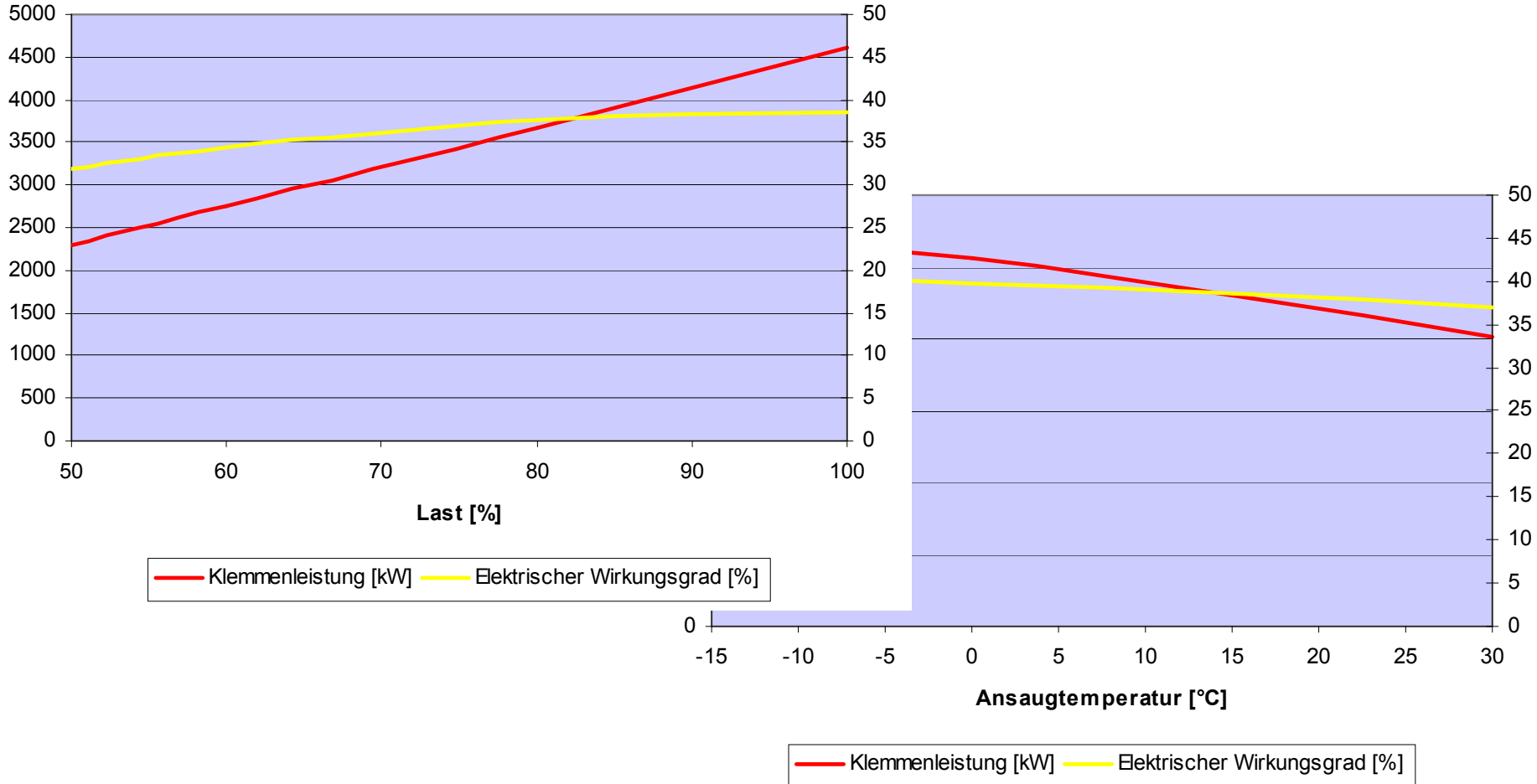

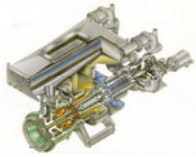

MERCURY 50 – Anwendungsfall: Sattdampferzeugung

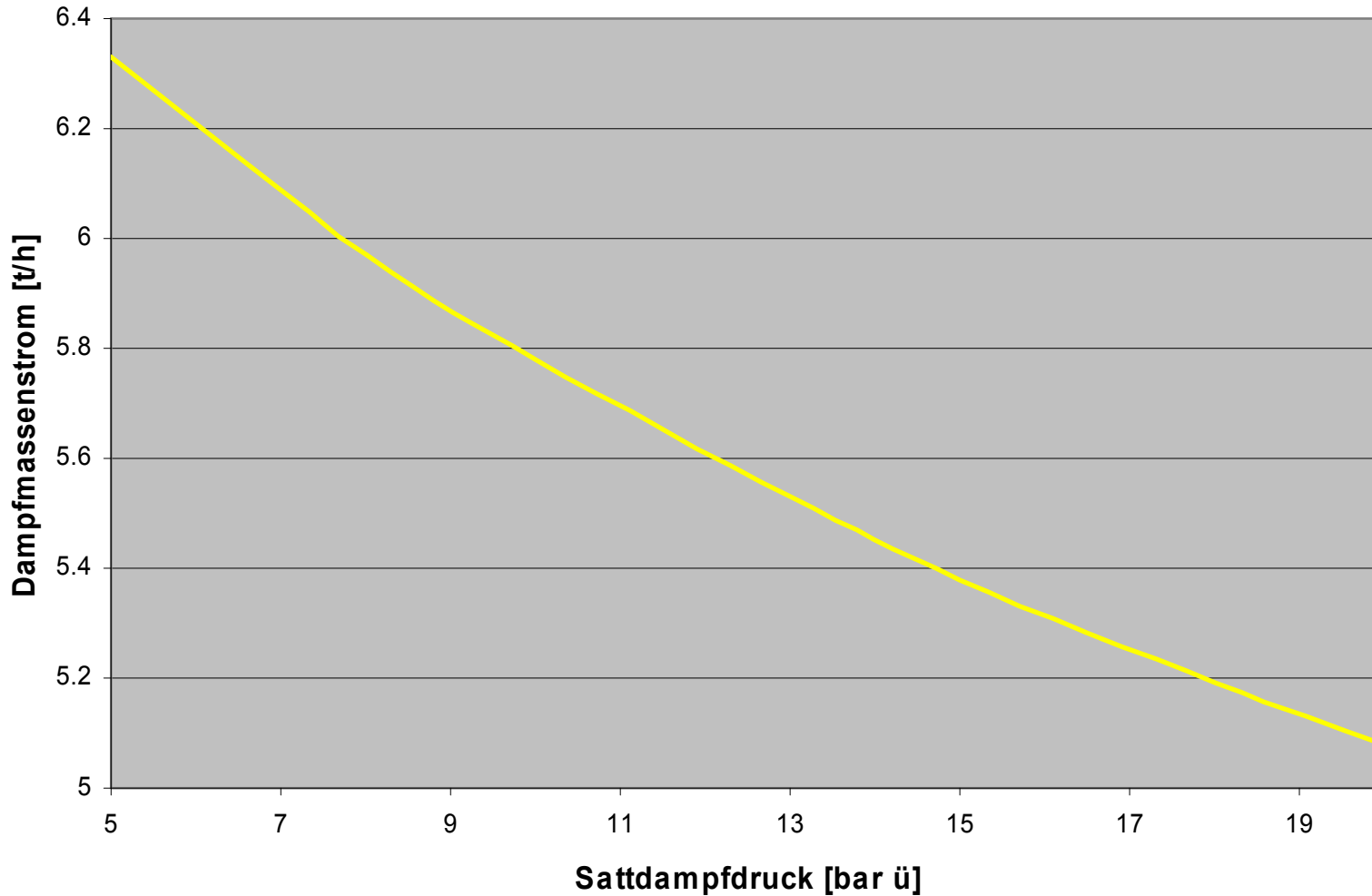

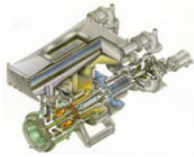

MERCURY 50 – Anwendungsfall: Satttdampferzeugung

Turbomach

A Caterpillar Company

LHV Fuel : 47'940 kJ/kg

Std. Natural Gas : 11'948 kW

Air : 15°C

Evap. Cooler
(Not Applied)

15°C

4'600 kWe

MERCURY 50

Process Steam Flow : 20'000 kg/h

Thermal Power Available : 13'935 kW

15 barG / Saturated Steam

374 °C
0.09 kg/s

17.73 kg/s
374°C

Burner Temp. : 1'816°C

Std. Natural Gas : 9'339 kW

Waste Heat
Recovery Boiler

Cond : 16'172 kg/h / 80°C

Make-up : 4'043 kg/h / 20°C

68°C

1'345 kg/h

21'345 kg/h

105°C

105°C

17.93 kg/s

124°C

Blowdown : 1'216 kg/h

Nominal Plant Efficiency : 87.07 %

Dampfproduktion ohne ZF: ca. 5 t/h
 Dampfproduktion mit ZF: Bsp. 20 t/h

Energy in all we do

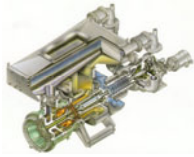

Packagekonzept Mercury 50

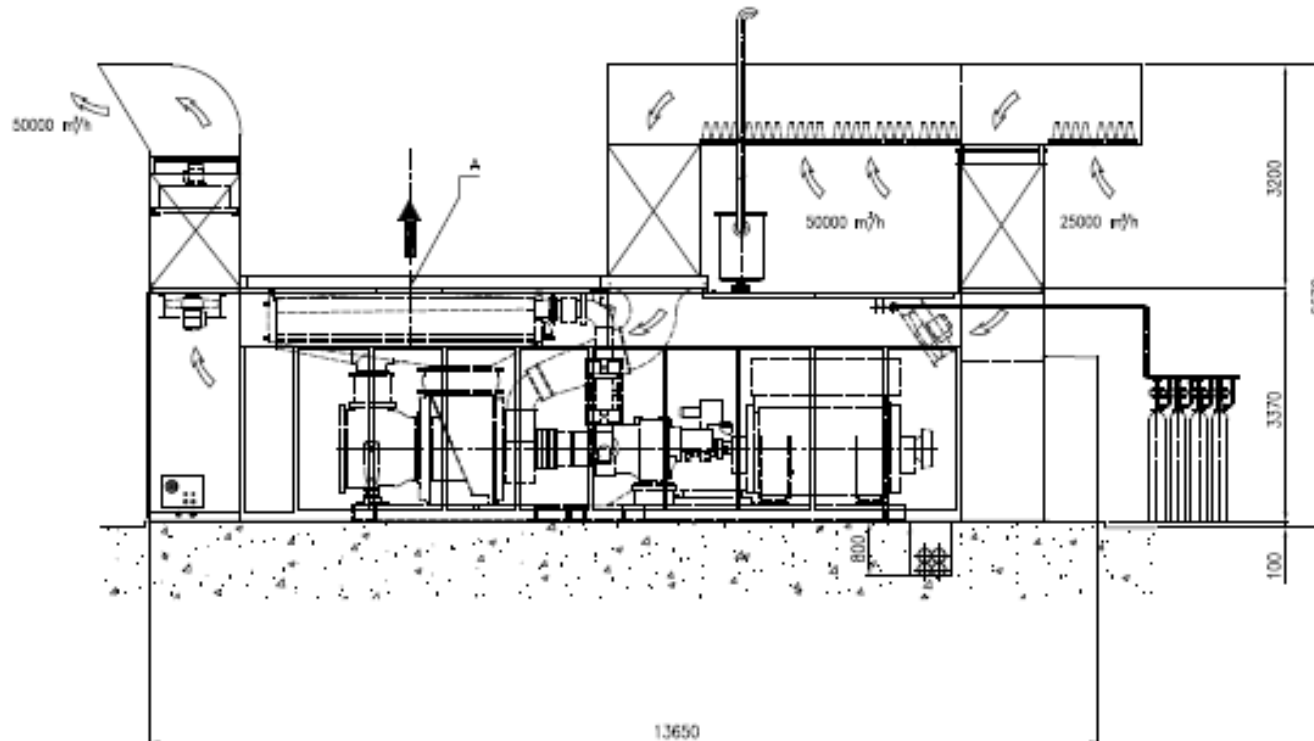

- „Single Lift“ – Konzept
- Schwingungsentkoppelung von Fundament durch Tellerfederpakete
- komplett vormontiert
- einfache Schnittstellen
- witterungsunabhängige Schallschutzhaube

Energy in all we do

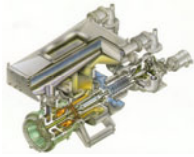

MERCURY 50 – Installationsbeispiel

Universität, Frankreich



Energy in all we do

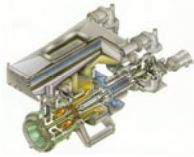

MERCURY 50 – Zusammenfassung

Typische Anwendungsfälle

- **Gasturbinen Heizkraftwerk**
- **Kraft- Wärme- Kälte- Kopplung**
- **Heißgaserzeugung für**

Trocknungsprozesse

- **Anwendungsfälle mit hohem Strom- und variablem Dampfbedarf**

Vorteile

- **hoher elektrischer Wirkungsgrad**
- **sehr gutes Teillastverhalten**
- **geringe Emissionen über weiten Lastbereich**
- **Wartungsfreundlichkeit**

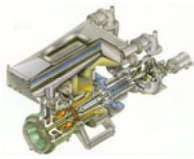

MERCURY 50 – Referenzen (Stand August 2009)

Land

USA 28

Europa 20

Gesamt 48

davon in

Deutschland 3

Frankreich 4

Italien 6

Spanien 1

Österreich 2

Türkei 1

Polen 1

Belgien 1

Grossbritannien 1

WATT'S THE FUTURE



Energy in all we do

Developments

Turbomach
A Caterpillar Company



WATT'S THE FUTURE - DEVELOPMENTS

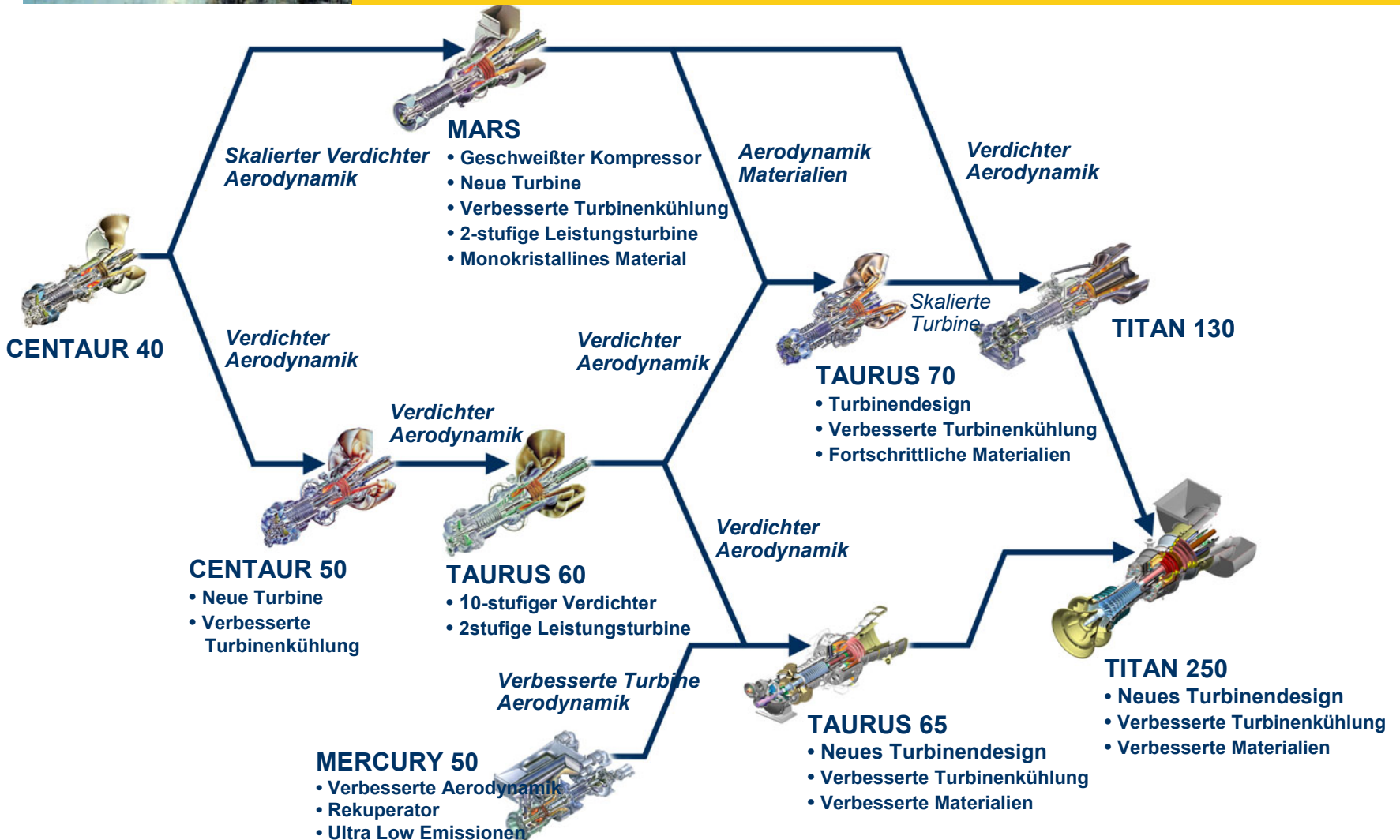

Energy in all we do



Saturn

1.2 MW
24.3 %

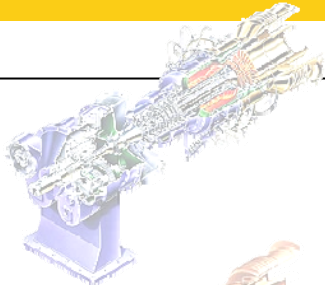

Taurus 70

7.5 MW
33.8 %

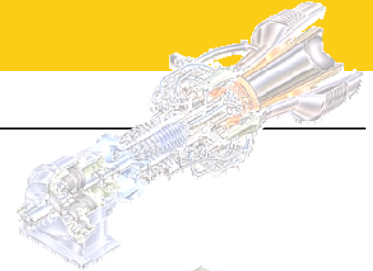

Centaur 40 / 50

3.5 / 4.6 MW
28 / 29.3 %

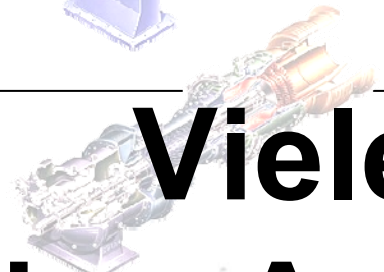

Mars 90 &100

9.4 / 11.4 MW
31.5 / 33 %

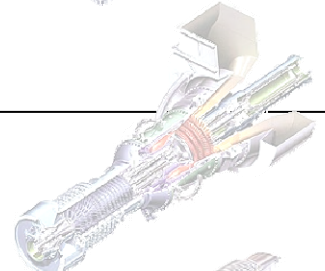

Vielen Dank für Ihre Aufmerksamkeit.

Mercury 30

4.6 MW
38.5 %

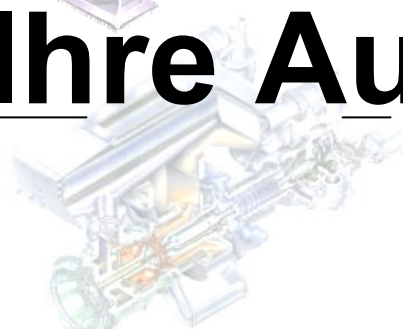

Sitar 130

15 MW
35.2 %

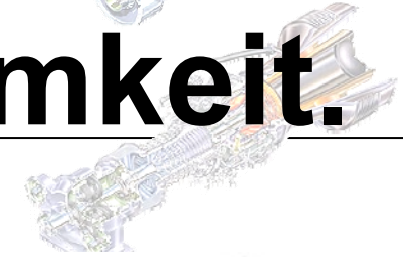

Taurus 60 / 65

5.6 / 6.3 MW
31.5 / 32.9 %

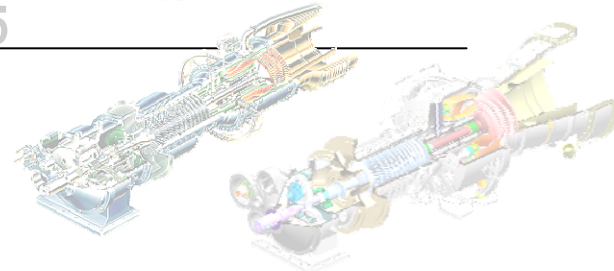

Titan 250

21.7 MW
38.8 %

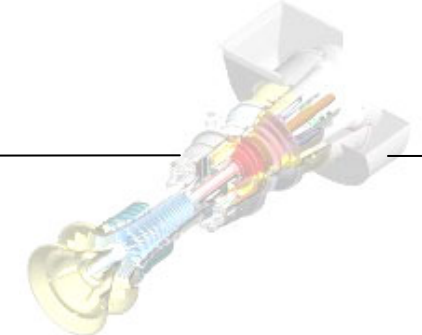

Energy in all we do

Turbomach
A Caterpillar Company

Turbomach

A Caterpillar Company